

WRAPPED BALE CLAMP

AGRICULTURAL HANDLING Solutions



ADVANTAGES

- Easy to use and competitive attachment.
- Powerful double effect cylinder allows the manipulation of very heavy bales.
- Rounded and articulated clamp designed to fit the shape of every bale.
- Smooth structure that avoids any perforation of plastic film.

TECHNICAL CHARACTERISTICS

- Self-lubricated anti-wear ring that improves the longevity of the attachment.
- Excellent lifting capacity up to 1000 kg.
- Welded monobloc chassis.
- Handles wrapped bale with diameter from 1 m to 1,7 m.

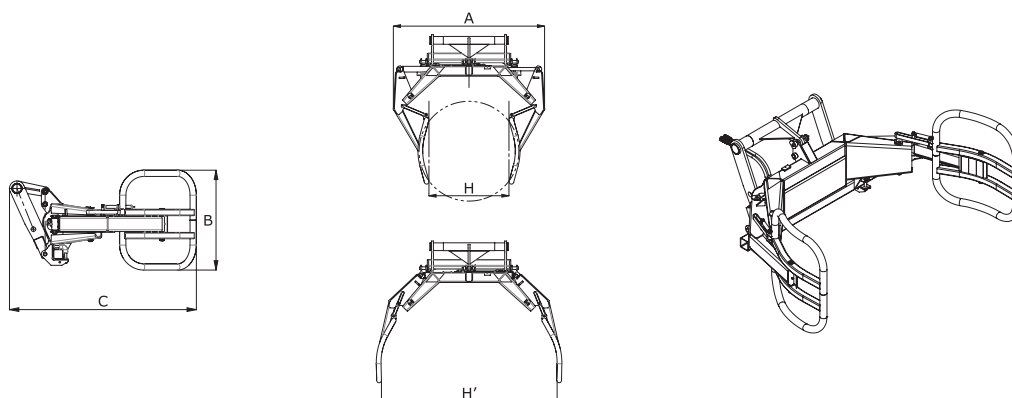

	Capacity (kg)	A	B	C	H	H'	Weight (kg)
PBE	1000	1600	805	1491	970	1846	242

COMPATIBILITY*

	PBE
Part Number	757613
MLT 625	X
MLT 629	X
MLT 634	X
MLT 735	X
MLT 840	X
MLT 845	X

* This Attachment has been approved for the MLT listed above. A load chart Machine/Attachment has been created accordingly.



This brochure describes versions and configuration options for Manitou products which may be fitted with different equipment. The equipment described in this brochure may be standard, optional or not available depending on version. Manitou reserves the right to change the specifications shown and described at any time and without prior warning. The manufacturer is not liable for the specifications given. For more information, contact your Manitou dealer. Non-contractual document. Product descriptions may differ from actual products. List of specifications is not comprehensive. The logos and visual identity of the company are the property of Manitou and may not be used without authorisation. All rights reserved. The photos and diagrams contained in this brochure are provided for information only. MANITOU BF SA - Limited company with board of directors - Share capital: 39,547,824 euros - 857 802 508 RCS Nantes

PBE_EN_B_0213



www.manitou.com