

# BALE CLAMP SUPER COMPACT

AGRICULTURAL HANDLING Solutions



## ADVANTAGES

- Easy to use and durable attachment.
- Very compact clamp.
- Rounded teeth in wrought iron that offer an accurate and clean penetration on materials.
- Optional: 2 lower teeth (680 mm, Ø 35) that give the possibility to handle rectangular bales.

## TECHNICAL CHARACTERISTICS

- 2x2 teeth.
- Non-synchronized closure.
- Good lifting capacity of 800 kg.
- Handles round bales with diameter up to 1,6 m maximum.

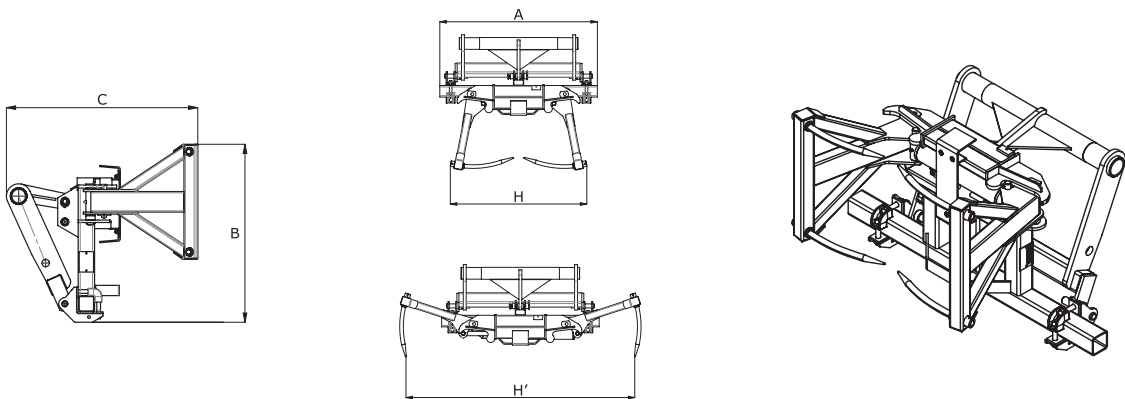

	Capacity (kg)	A	B	C	H	H'	Weight (kg)
PBG2x2	800	1090	869	935	944	1583	158

## COMPATIBILITY\*

	PBG2x2
Part Number	757639
MLT 625	X
MLT 629	X
MLT 634	X
MLT 735	X
MLT 840	X
MLT 845	X

\* This Attachment has been approved for the MLT listed above. A load chart Machine/Attachment has been created accordingly.



This brochure describes versions and configuration options for Manitou products which may be fitted with different equipment. The equipment described in this brochure may be standard, optional or not available depending on version. Manitou reserves the right to change the specifications shown and described at any time and without prior warning. The manufacturer is not liable for the specifications given. For more information, contact your Manitou dealer. Non-contractual document. Product descriptions may differ from actual products. List of specifications is not comprehensive. The logos and visual identity of the company are the property of Manitou and may not be used without authorisation. All rights reserved. The photos and diagrams contained in this brochure are provided for information only. MANITOU BF SA - Limited company with board of directors - Share capital: 39,547,824 euros - 857 802 508 RCS Nantes

PBG2x2\_EN\_B\_0213



# MANITOU

www.manitou.com