

# EXPANDABLE PLATFORM

PEOPLE UPLIFTING and HANDLING solutions

## ADVANTAGES

- Flexibility on aerial working situations.
- Different working widths available 4, 5 and 6 meters.
- Heavy duty and galvanised structure for an improved longevity.
- Non-slip metal flooring.
- Expandable sides are independent.
- Easy to move while unused thanks to 2 forks sleeves.

## TECHNICAL CHARACTERISTICS

- Capacity from 365 to 1000kg.
- Slewing platform + / - 90°.
- Legally approved for 3 persons.
- Accessible from 3 sides.
- Overload sensor.

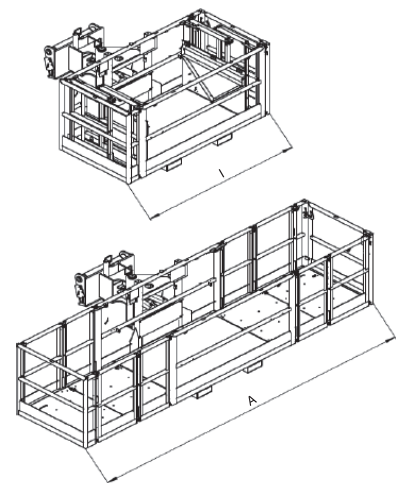
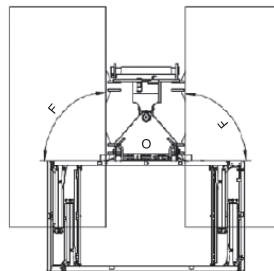
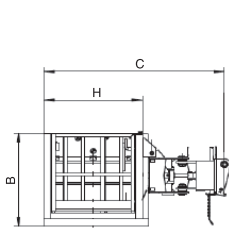

	Capacity (kg)	A	B	C	H	I	F (degrees)	Persons	Weight (kg)
NAC 2,25/4M 365 kg	365	4000	1320	2340	1210	2250	+/-90°	3	700
NAC 2,25/4M 1000 kg	1000	4000	1300	2230	1200	2250	+/-90°	3	1050
NAC 2,45/5M 1000 kg	1000	5000	1300	2230	1200	2450	+/-90°	3	1150
NAC 2,45/6M 365 kg	365	6000	1300	2230	1200	2450	+/-90°	3	1210

## COMPATIBILITY\*

	NAC 2,25/4M 365 kg	NAC 2,25/4M 1000 kg	NAC 2,45/5M 1000 kg	NAC 2,45/6M 365 kg
Part Number MT	788783	788785	788786	788784
MT 1135 HA	X	X	X	X
MT 1335 HA	X	X	X	X
MT 1440 A / HA	X	X	X	X
MT 1840 A / HA	X	X	X	X
Part Number MRT	711204	658941	688136	688137
MRT EASY	X	X	X	X
MRT PRIV	X	X	X	X
Part Number MRT +	921298	921306	921308	921310
MRT + PRIV	X	X	X	X

\* This Attachment has been approved for the MT and MRT listed above. A load chart Machine/Attachment has been created accordingly.

This brochure describes versions and configuration options for Manitou products which may be fitted with different equipment. The equipment described in this brochure may be standard, optional or not available depending on version. Manitou reserves the right to change the specifications shown and described at any time and without prior warning. The manufacturer is not liable for the specifications given. For more information, contact your Manitou dealer. Non-contractual document.

Product descriptions may differ from actual products. List of specifications is not comprehensive. The logos and visual identity of the company are the property of Manitou and may not be used without authorisation. All rights reserved. The photos and diagrams contained in this brochure are provided for information only.

MANITOU BF SA - Limited company with board of directors - Share capital: 39,547,824 euros - 857 802 508 RCS Nantes

NAC\_EXT\_EN\_B\_0413



 **MANITOU**

www.manitou.com