

BENNE À BÉTON

Solutions de MANUTENTION de CHANTIERS

AVANTAGES

- Une benne adaptée aux besoins des professionnels du BTP.
- Accessoire compact permettant le travail dans les embrasures de fenêtres.
- Polyvalent, pour ciment et mortier.
- Option : déversement hydraulique et/ou goulotte (1 m, Ø 200 mm) pour une excellente précision de travail.

TECHNICAL CHARACTERISTICS

- Capacité 500 L.
- Accroche directe sur le tablier ou sur fourche.
- Sécurité : accessoire muni d'un système de blocage de fourche.

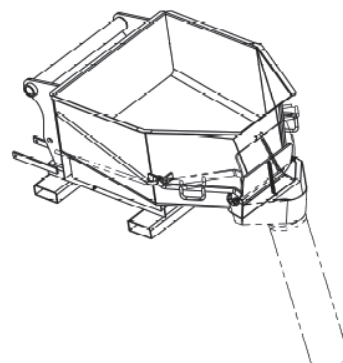
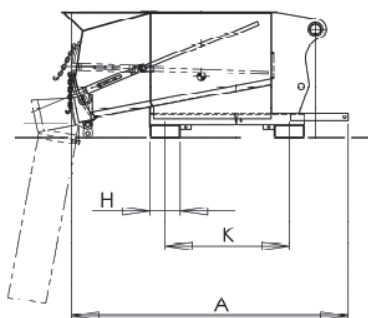
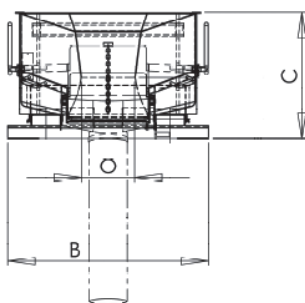

	Capacité (L)	A	B	C	H	K	O	Goulotte	Ouverture hydraulique	Poids (kg)
BB 500	500	1570	1100	747	155	680	290			205
BBH 500	500	1570	1100	747	155	680	290		OUI	220
BBG 500	500	1570	1100	747	155	680	290	OUI		220
BBHG 500	500	1570	1100	747	155	680	290	OUI	OUI	235

COMPATIBILITÉ*

	BB 500	BBH 500	BBG 500	BBHG 500
Réf Commerciale MT	654409	751462	654411	751464
MT 625	X	X	X	X
MT 732	X	X	X	X
MT 835	X	X	X	X
MT 932	X	X	X	X
MT 1030	X	X	X	X
MT 1135	X	X	X	X
MT 1235	X	X	X	X
MT 1335	X	X	X	X
MT 1440	X	X	X	X
MT 1740	X	X	X	X
MT 1840	X	X	X	X
Réf Commerciale MRT	654409			725011
MRT EASY	X			X
MRT PRIV	X			X
Réf Commerciale MRT +	921269			921270
MRT + PRIV	X			X

* Cet accessoire a été approuvé pour les MT & MRT citées ci-dessus et par conséquent un abaqué de charge Machine/Accessoire a été créé.

This brochure describes versions and configuration options for Manitou products which may be fitted with different equipment. The equipment described in this brochure may be standard, optional or not available depending on version. Manitou reserves the right to change the specifications shown and described at any time and without prior warning. The manufacturer is not liable for the specifications given. For more information, contact your Manitou dealer. Non-contractual document.

Product descriptions may differ from actual products. List of specifications is not comprehensive. The logos and visual identity of the company are the property of Manitou and may not be used without authorisation. All rights reserved. The photos and diagrams contained in this brochure are provided for information only.

MANITOU BF SA - Limited company with board of directors - Share capital: 39,547,824 euros - 857 802 508 RCS Nantes

BB_FR_B_0413



 **MANITOU**

www.manitou.com