

PICK-UP SWEEPER BUCKET

AGRICULTURAL and BUILDING SITES HANDLING Solutions

ADVANTAGES

- Durable and easy to use.
- Sweep and pick-up in one operation.
- Up to 2500 m² cleaned in 10 minutes.
- High quality sweeping on uneven ground.
- Interchangeable side brush (right or left) for a perfect sweeping along wall and sidewalks.

TECHNICAL CHARACTERISTICS

- Floating frame which avoids any squashing of this attachment from the handling machine.
- ø 230 mm side brush in polyester and galvanized steel.
- System Easy to Drive: the JSM activates the sweeping but also the opening of the box collector.

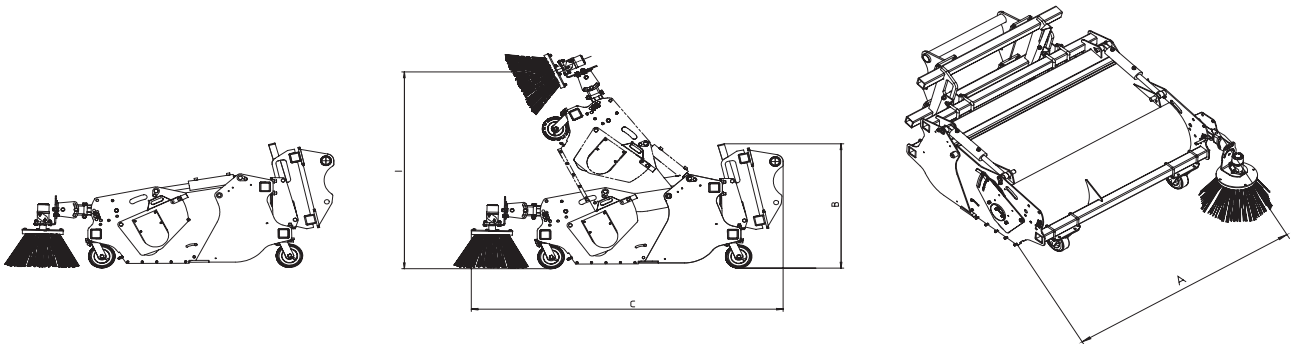

	Capacity (L)	A	B	C	I	Weight (kg)
BRB 1600	380	2000	1068	2370	1704	775
BRB 2200	530	2600	1068	2370	1704	925

COMPATIBILITY*

	BRB 1600	BRB 2200
Part Number	790313	790315
MLT 625	X	
MLT 634		X
MLT 735		X
MLT 840		X
MT 625	X	

* This Attachment has been approved for the MLT & MT listed above. A load chart Machine/Attachment has been created accordingly.



This brochure describes versions and configuration options for Manitou products which may be fitted with different equipment. The equipment described in this brochure may be standard, optional or not available depending on version. Manitou reserves the right to change the specifications shown and described at any time and without prior warning. The manufacturer is not liable for the specifications given. For more information, contact your Manitou dealer. Non-contractual document. Product descriptions may differ from actual products. List of specifications is not comprehensive. The logos and visual identity of the company are the property of Manitou and may not be used without authorisation. All rights reserved. The photos and diagrams contained in this brochure are provided for information only. MANITOU BF SA - Limited company with board of directors - Share capital: 39,547,824 euros - 857 802 508 RCS Nantes

BRB_EN_B_0413

 **MANITOU**

www.manitou.com