

FEEDING BUCKET

AGRICULTURAL HANDLING Solutions



ADVANTAGES

- Higher distribution rate.
- High speed discharge system.
- Versatility 2 in 1 attachment, a feeding bucket and a bale clamp.
- Low RPM engine: Lower fuel consumption.

TECHNICAL CHARACTERISTICS

- Hydraulic jaw for an optimal attack angle of the silo.
- Fitted auger for a better distribution.
- Operating solenoid valve.
- Drainage of tool-side motors for hydraulic circuit with back pressure > 50 bar.

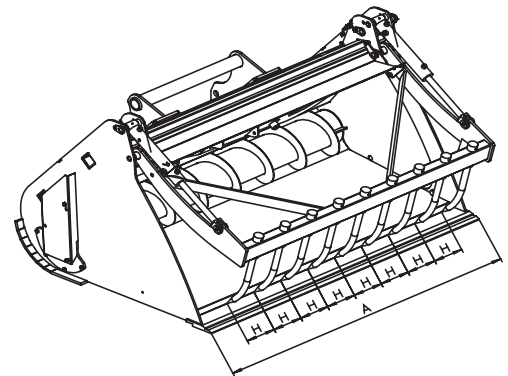
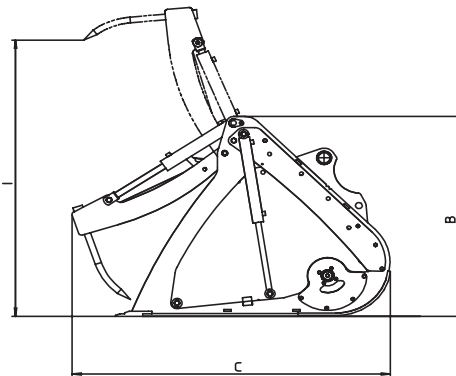
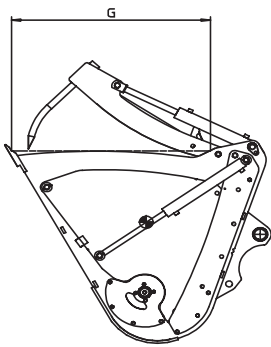

	Capacity (L)	A	B	C	G	H	I	Teeth	Weight (kg)
CGD 2200/1700	1700	2205	1238	1753	1083	204	1712	9	1025
CGD 2200/2100	2100	2205	1427	1901	1167	204	1984	9	1140
CGD 2500/2500	2500	2505	1427	1901	1167	204	1984	11	1240

COMPATIBILITY*

	CGD 2200/1700	CGD 2200/2100	CGD 2500/2500
Part Number	790310	790311	790312
MLT 625	X		
MLT 629		X	
MLT 634			X
MLT 735			X
MLT 840			X
MLT 845			X

* This Attachment has been approved for the MLT listed above.
A load chart Machine/Attachment has been created accordingly.



This brochure describes versions and configuration options for Manitou products which may be fitted with different equipment. The equipment described in this brochure may be standard, optional or not available depending on version. Manitou reserves the right to change the specifications shown and described at any time and without prior warning. The manufacturer is not liable for the specifications given. For more information, contact your Manitou dealer. Non-contractual document.
Product descriptions may differ from actual products. List of specifications is not comprehensive. The logos and visual identity of the company are the property of Manitou and may not be used without authorisation. All rights reserved. The photos and diagrams contained in this brochure are provided for information only.
MANITOU BF SA - Limited company with board of directors - Share capital: 39,547,824 euros - 857 802 508 RCS Nantes

CGD_EN_B_0213



www.manitou.com