

# CONCRETE MIXING BUCKET

BUILDING SITES HANDLING solutions

## ADVANTAGES

- Durable bucket designed for an intensive use.
- Bag opener incorporated into the cover.
- A mixture ready to use in 3 minutes.
- Adapted to dry mixtures.
- Replaceable mixing blades for low running costs.

## TECHNICAL CHARACTERISTICS

- Capacity 500 L.
- Bolt-on mixing blades in abrasion-resistant steel.
- Standard equipped with electric cable reel.
- 1.5 m flexible tube (standard) for better unloading control.
- Lateral distribution controlled hydraulically, that ensures maximum users security.

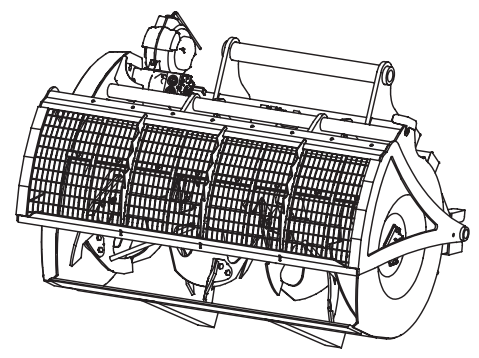
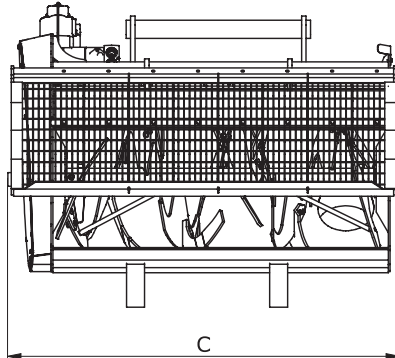
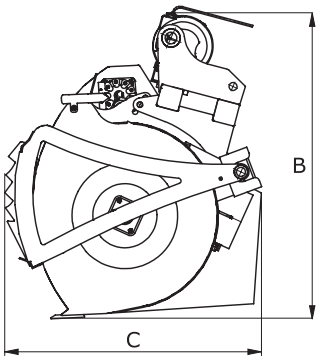

|                | Capacity (L) | A    | B    | C    | Weight (kg) |
|----------------|--------------|------|------|------|-------------|
| <b>BMC 500</b> | 500          | 1750 | 1112 | 1350 | 720         |

## COMPATIBILITY\*

|                    | BMC 500 |
|--------------------|---------|
| <b>Part Number</b> | 757637  |
| <b>MT 625</b>      |         |
| <b>MT 732</b>      |         |
| <b>MT 835</b>      | X       |
| <b>MT 1030</b>     |         |
| <b>MT 1135</b>     | X       |
| <b>MT 1235</b>     |         |
| <b>MT 1335</b>     | X       |
| <b>MT 1440</b>     | X       |
| <b>MT 1840</b>     | X       |

\* This Attachment has been approved for the MT listed above. A load chart Machine/Attachment has been created accordingly.

This brochure describes versions and configuration options for Manitou products which may be fitted with different equipment. The equipment described in this brochure may be standard, optional or not available depending on version. Manitou reserves the right to change the specifications shown and described at any time and without prior warning. The manufacturer is not liable for the specifications given. For more information, contact your Manitou dealer. Non-contractual document.

Product descriptions may differ from actual products. List of specifications is not comprehensive. The logos and visual identity of the company are the property of Manitou and may not be used without authorisation. All rights reserved. The photos and diagrams contained in this brochure are provided for information only.

MANITOU BF SA - Limited company with board of directors - Share capital: 39,547,824 euros - 857 802 508 RCS Nantes

BMC500\_EN\_A\_0313



# MANITOU

www.manitou.com